

## Water Fuel Injector: Taper Resonant Cavity

Tuning-in to the dielectric properties of water by way of voltage stimulation allows a sequent of events to occur in a instant of time:

Superimposing "Electrical Stress" of opposite voltage polarity to switch-off covalent bonding to perform Electrical Polarization Process of water.

Propagating the use of Universal Energy by " Energy - Aperture" oscillation of the release combustible gas atoms of water.

Encouraging particle oscillation as an "Energy Generator" to further "Energy Prime" the combustible gas ions prior to gas-ignition once electron ejection occurs.

Triggering the highly "energized" combustible gas atoms of water by way of "atomic electrical discharged" as an ever increasing electrostatic pressure of opposite voltage polarity under pulse resonance is applied across the water molecule ... releasing thermal' explosive energy (gtnt) on demand in the following way:

## Water Fuel Injector (Taper Resonant Cavity)

Voltage potential of opposite electrical polarity ( $ST - ST' - RU - RU'$ ) of Figure (5-1) (Memo WFC 424 ) titled "Atomic Energy Balance of Water" is further enhanced by simply electrically interfacing voltage intensifier (VIC) circuit coil-assembly (580) of Figure (6-1) with "Taper Resonant Cavity" (590) of Figure (6-2), as schematically illustrated in (60) of Figure (3-22) as to pulse core configuration (190) of Figure (3-23) (Memo WFC 422 DA) titled "WFC Hydrogen Gas Management System.

As incoming gated pulse-train (46a xxx 46n) of Figure (3-17) is electronically "tuned" to adjust pulse off-time ( $T_2$ ) to compensate for "rise" and "fall" of magnetic field coupling (71a xxx 71n) for a predetermined resonant pulse-frequency established and determined by the dielectric value of natural water in direct relationship to resonant cavity geometrical configuration ... dielectric value of water being 78.54 since water molecule (85) oxygen atom "L" orbit (76) occupies the maximum allowance eight electrons (79a xxx 79n), calibrated gated unipolar pulse train (64a xxx 64n) of Figure (3-20) is outputted from resonant choke (56) and electrically transmitted to positive outer conical surface (E9); while, at the same time, negative potential of electrical intensity of force (67) (negative voltage potential) is electrically directed to inner conical surface (E10), forming an "open-air" conical cavity (570) having parallel sides (in other cases non-linear voltage-surfaces) in space relationship (typically .010 gap) with diminishing circumference-area (E9a xxx E9n) / E10a xxx E10n) in linear progression. Together, parallel sides (E9 / E10) not only functions as a "voltage wave-guide" (570) but, also, acts and performs as a "voltage intensifier circuit" when applied gated pulse-frequency (64a xxx 64n) travels the length of conical cavity (570) toward exit port (32). At each progressive point of diminishing circumference surface-area (E9a - b - c - d - E9n) voltage amplitude intensity increases ( $V_{na} - b - c - d - V_{nn}$ ) uniformly, as illustrated in (600) of Figure (6-3) as to Travelling Voltage Wave-forms (730a - b - c) of Figure (7-12), see WFC Memo (426).

Activation point (E9a) exposes water flow (85) to voltage wave-form (64) of Figure (6-1) to begin water-to-energy conversion process (100); at activation point (E9b) voltage intensity is

increased sufficiently to perform Electrical Polarization Process (160) of Figure (3-26); onward toward activation point (E9c) and beyond universal energy priming stage (500) of Figure (5-1) occurs; once activation point (E9c) is reached Gas Ionization Process (230) of Figure (3-30) takes place; and finally, activation point (E9d) thermally ignites (atomic agitation) the "Energy-Primed" combustible gas-mixture (520) of Figure (5-3) as to (100) of Figure (4-8) by "electrostatic discharge" while being subjected to ever increasing "electrostatic pressure". All activation points (E9a - b - c - d) performing their respective functions in sequential order in an instant of time since applied voltage level of intensity (typically 20,000 input volts or so) can be extended or increased up to and beyond 90,000 volts range within a millisecond or less.

#### Taper Water Fuel Injectors

Voltage wave-guide (570) allows the activation points (E9a xxx E9n) to transpire since wave-guide (570), now, functions as a Quenching Circuit (370) of Figure (3-40) to prevent gas ignition until the travelling gases (under static pressure) are exited out of and away from exit port (32) of Figure (6-2) ... producing thermal explosive energy-yield (16), as further illustrated in (70) of Figure (4-5) titled "Voltage Triggering". Basically, then, activation process (590), now, design - forms Water Fuel Injector (20) of Figure (4-2) as to (30) of Figure (4-11) (Memo WFC 423 DA) ... allowing Water Fuel Injectors (20a xxx 20n) to replace standard Internal Combustion Engine spark-plugs and fossil-fuel injector ports, as graphically illustrated in Figure (140) of Figure (4-12) titled "Furnace Retrofit," (150) of Figure (4-13) titled "Jet Engine retrofit," and (160) of Figure (4-14) titled "Rocket Engines Retrofit."

#### Voltage Intensifier Coil-Assembly

Activation Process (590) of Figure (6-2) as to (100) of Figure (4-8) is achieved since amp flow is restricted to enter into Voltage Triggering Process (70) of Figure (4-5) by way of voltage intensifier coil-assembly (580) of Figure (6-1). Inherently, the design parameters of coil-structures (580) of Figure (6-1) determines "Efficiency" (minimizing amp leakage) by which "Voltage Intensity of Opposite Potential" (600) of Figure (6-3) can perform work to trigger Hydrogen Fracturing Process (520) of Figure (5-3) (Memo WFC 424 DA) as to (100) of Figure (4-8) (Memo WFC 423DA), as graphically denoted in (750) of Figure (7-14) of WFC memo (425) titled VIC Matrix Circuit - Instant Explosion of Water.

### Tri - Coil Construction

Resonant Choke Coils (56/62) of Figure (3-23) (Memo WFC 422 DA) are composed of 430F or 430FR inductance stainless steel film coated (hi dielectric value) wire (typically .004 Ga. or smaller) which are axially (spiralled) Bifilar wound about core bobbin (502), forming individual spiral-wrap (inner to outer circumference and being equally-length) coils (501a xxx 501n) electrically connected in sequential order to form resistive pickup coil (503).

Primary Coil (26) (typically .030 Ga.) film coated magnet wire is longitudinal wrapped in space relationship on top of and layered bidirectional (507a xxx 507n) across spiral-wrap coils (501a xxx 50 In) to complete bobbin cavity (504).

Secondary pickup coil (52) of Figure (3-23) is, also, composed of individual spiral wrapped coils (505a xxx 505n) (typically .002 Ga. magnet wire) electrically connected in sequential order to form bobbin cavity (506) which is placed on top of and in space relationship to primary coil cavity (504).

Resonant bobbin assembly (503), primary bobbin assembly (504), and secondary bobbin assembly (506), now, make up and structurally forms voltage intensifier (VIC) coil-assembly (530) of Figure (4-6) when electrical steel core material (53) forms a close-loop magnetic induction pathway centrally through and around (VIC) coil-assembly (530), as schematically illustrated in (190) of Figure (3-23) (Memo WFC 422 DA).

### Electromagnetic Interaction

The resultant tri-coil configuration (Inductance core 53 - choke coils 56/62 - primary coil 26 - secondary coil 52), now, allows magnetic field coupling (71a xxx 71n) to pass through both resonant-coils (56/62) and secondary coil (52) simultaneously when primary coil (26) is pulsed energized by way of incoming pulse-train (46a xxx 46n). In doing so, magnetic flux-lines (71a xxx 71n) are induced into spiral-wrap coils (505a xxx 505n) to produce inductance coupling (511a xxx 51 In) between each secondary spiral-coils (505a xxx 505n) which are parallel formed to expanding magnetic flux-lines (71a xxx 71n) ... producing step up voltage potential of positive

electrical intensity (positive voltage potential) by way of inductance / capacitance interaction across secondary coil-assembly (52) while keeping opposition to electromagnetic build up to a minimum.

Magnetic flux-lines (71a xxx 71n) being emitted on the opposite side of primary coil (26) induces further increase in positive voltage potential (64 a xxx) since inductance / capacitance (Cd / DL) of Figure (7-3) interaction is, also, occurring in both resonant charging chokes simultaneously in balance relationship to the same pulse sequent (46) ... producing inductance coupling (512a xxx 512n) (Rp /Rpl/Rp2) of Figure (7-8) in parallel relationship to expanding field (71), as before. The resultant Pulsing Sequence (49a xxx - T1/T2 -xxx 49n) of Figure (7-1) allows voltage (T1) across Inductance Chokes (56/62) while current flow lags by 90°.

Together, external magnetic field (71), inductance coupling field (512a xxx 512n), resistive value ( $Z2 + Z3$ ) of stainless steel wire-coil (56/62), and the dielectric value (ohmic or resistive value) ( $Re >$  of water aids and performs amp restriction process (520) of Figure (5-3) while allowing applied voltage amplitude to be electrically transmitted without signal degradation. (see circuit resistive equations (Eq 9) ( Memo WFC 420, once again) as to VIC Matrix Circuit (690) of Figure (7-8).

The resultant dynamic voltage potential (600) of Figure (6-3) , now, performs the Hydrogen Fracturing Process. (390) of Figure (3-42) (Memo WFC 422 DA) in such a way as to allow particle oscillation to take place as a "Energy Generator" (see Memo WFC 424 titled Atomic Energy Balance of Water) to further enhance thermal explosive energy-yield (16a xxx 16n) (70) of Figure (4-5) (Memo.WFC 423 DA), as graphically illustrated in (610) of Figure (6-4).

Injector (590) of Figure (6-2) and voltage intensifier coil-circuit (580) of Figure (6-1) as to (190) of Figure (3-23) is electronically Interlinked with Water Fuel Management (WFMS) System (40) of Figure (4-2) (Memo WFC 423DA) to form "The Water Fuel Injection System" ® that triggers and performs voltage activation process (600) of Figure (6-3) as to (730) of Figure (7-12).

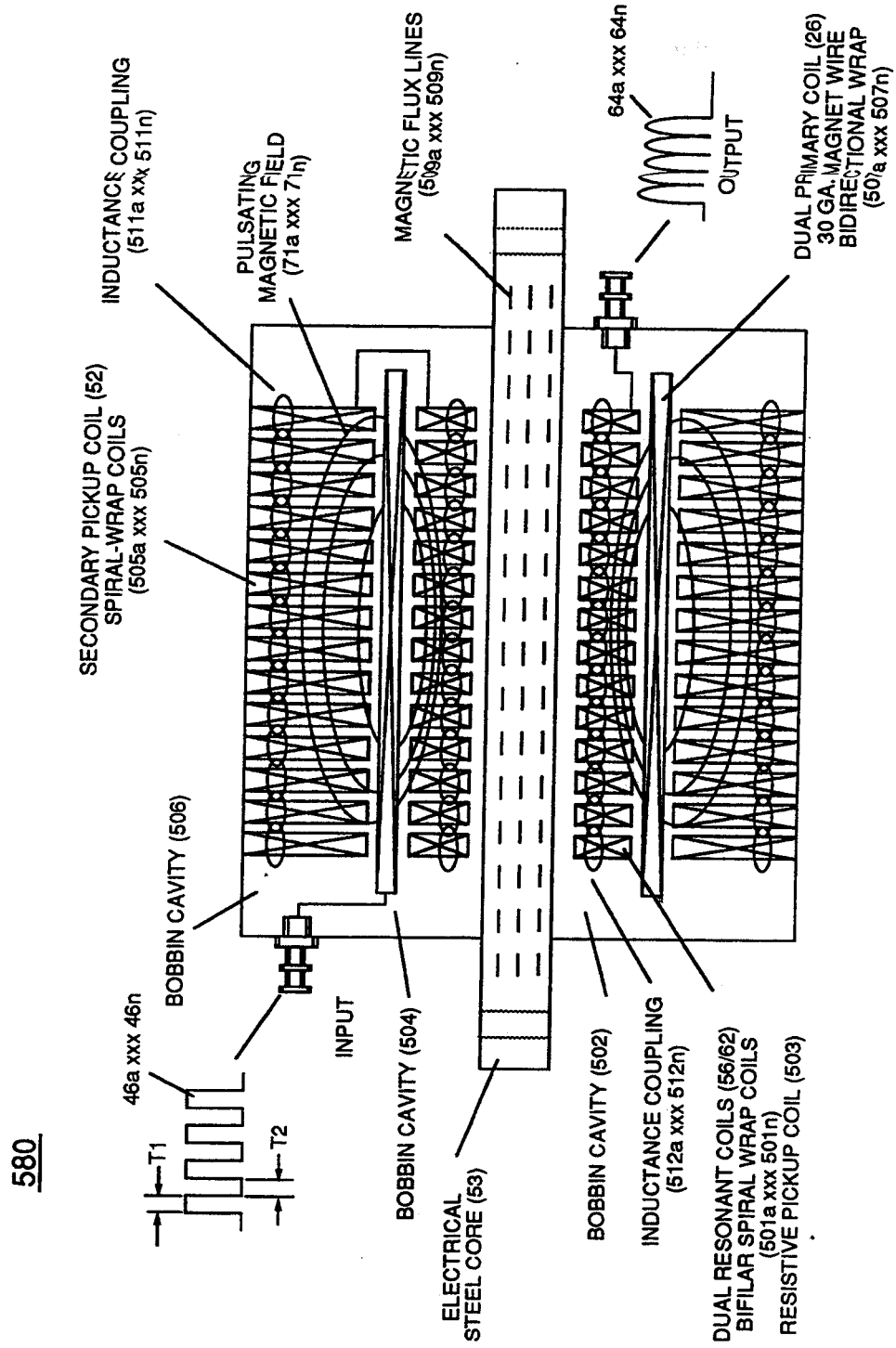
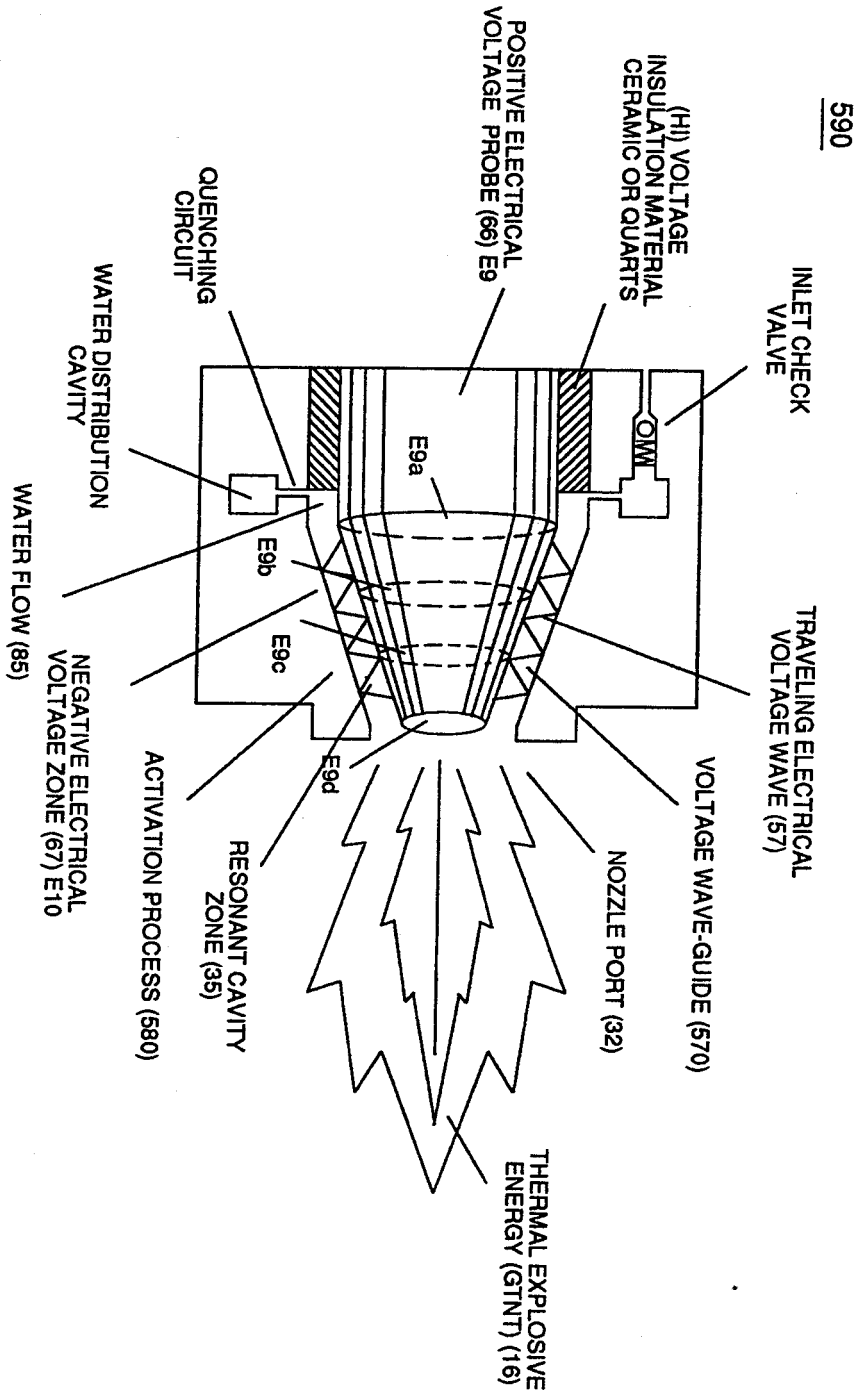

FIGURE 6-1: (VIC) COIL ASSEMBLY



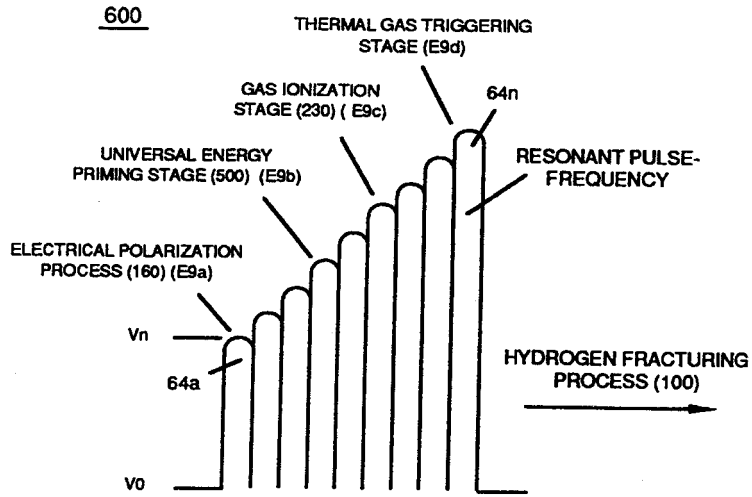

FIGURE 6-3: DYNAMIC VOLTAGE POTENTIAL

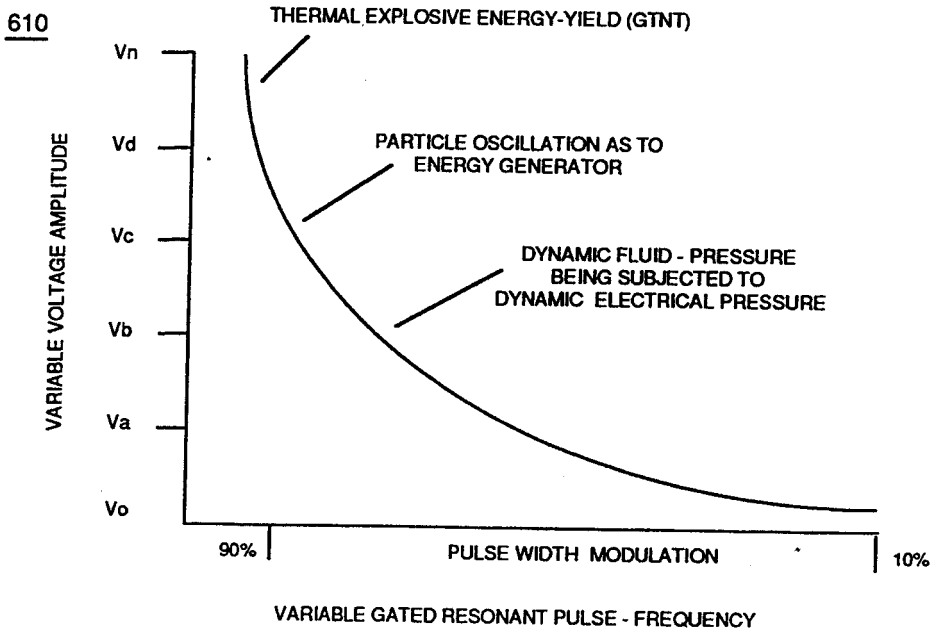

FIGURE 6-4: PARTICLE OSCILLATION AS TO ENERGY GENERATOR